

1 2 3 4 5 6 7 8 9 10

A

B

C

D

E

F

A

B

C

D

E

F

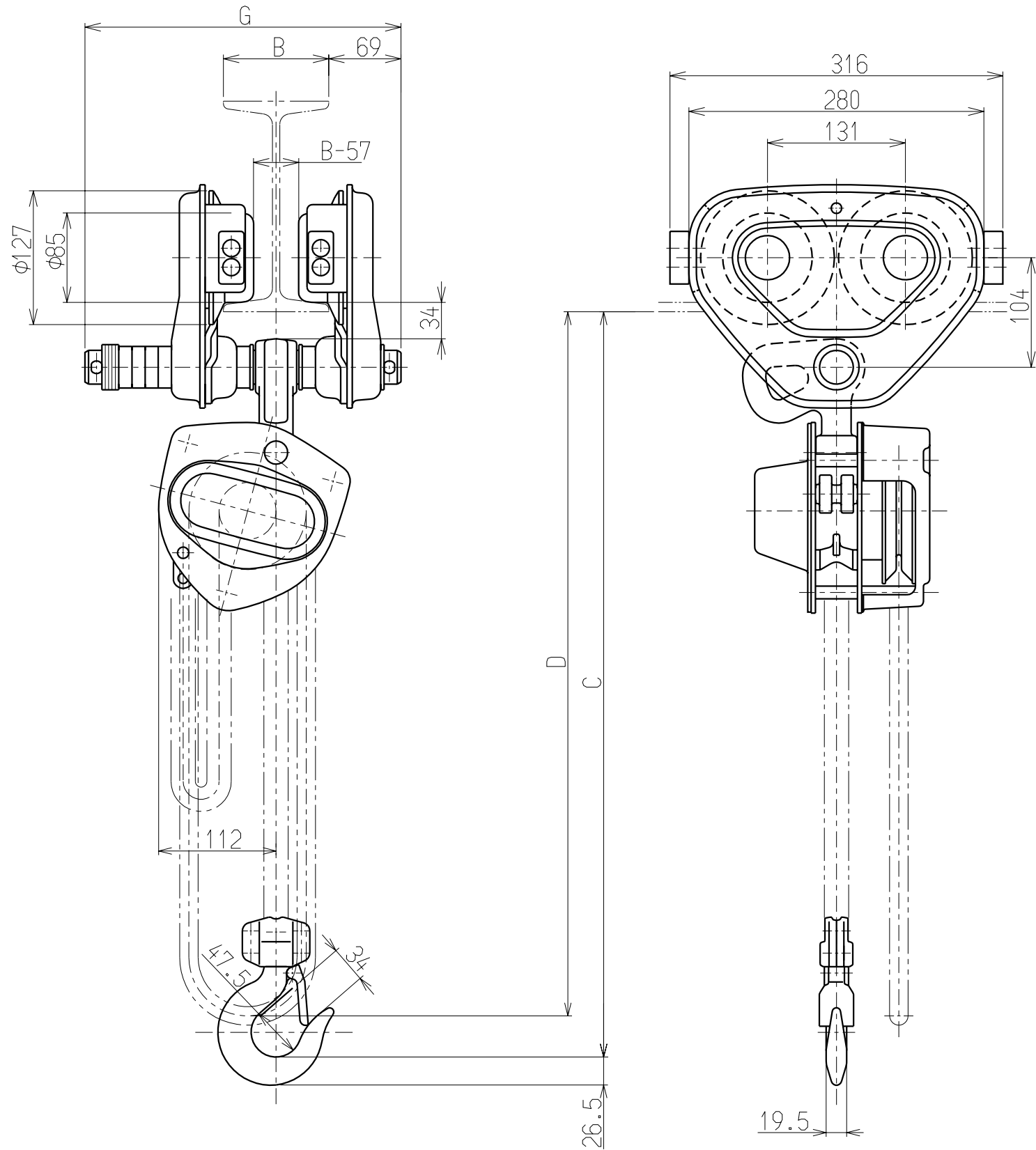

Particulars		
Nominal Capacity	1.5 t	
Lift	2.5 m	
Min. Headroom : C	365 mm	
Chain Pull to Lift Full Load	343 N (35 kg)	
Hand Chain Length from Bottom of Beam : D	2.5 m	
Min. Radius for Curve	1500 mm	1600 mm
Flange Width : B	82~153mm	154~305mm
Max. Dimension of Trolley Width : G	300 mm	450 mm
Mass	28 kg	29 kg

Note:  
The trolley can be installed on either tapered or flat flange.

1.5 t CBSP SERIES CHAIN HOIST WITH PLAIN TROLLEY			
CODE	CBSP015	SCALE	1/5
DWG.NO.	C3BG015T7P-12100	DATE	

APPROVED	CHECKED	DESIGNED
SAITO 2007.10.26	OZAWA 2007.10.26	NAITO 2007.10.26
<b>KITO CORP.</b>		

UNIT : mm