



**User Instruction Manual for:**  
**Saflok® Concrete Wedge Anchor**  
 (Model Numbers: 2100085, 2100085C)

## **USER INSTRUCTION MANUAL**

### **SAFLOK® CONCRETE WEDGE ANCHOR**

This manual is intended to meet the Manufacturer's Instructions as required by ANSI Z359.1 and should be used as part of an employee training program as required by OSHA.

**WARNING:** *This product is part of a personal fall arrest, restraint, work positioning, personnel riding, or rescue system. The user must follow the manufacturer's instructions for each component of the system. These instructions must be provided to the user of this equipment. The user must read and understand these instructions before using this equipment. Manufacturer's instructions must be followed for proper use and maintenance of this equipment. Alterations or misuse of this equipment, or failure to follow these instructions, may result in serious injury or death.*

**IMPORTANT:** *If you have questions on the use, care, or suitability of this equipment for your application contact Capital Safety.*

**IMPORTANT:** *Record the product identification information from the ID label in the Inspection and Maintenance Log in Section 9.0 of this manual.*

### **DESCRIPTION**

The Saflok® Concrete Wedge Anchor (Figure 1) is a reusable anchor point for horizontal, vertical, or overhead concrete applications. The anchor's End Termination expands Wedges to secure the anchor in a 3/4 inch (19.05 mm) mounting hole. A spring-tensioned Trigger and Retractor Cables release the Wedges to allow immediate removal and relocation to another hole. A Swivel Ring serves as the connection for Fall Arrest, Work Positioning, Restraint, or Personnel Riding systems.

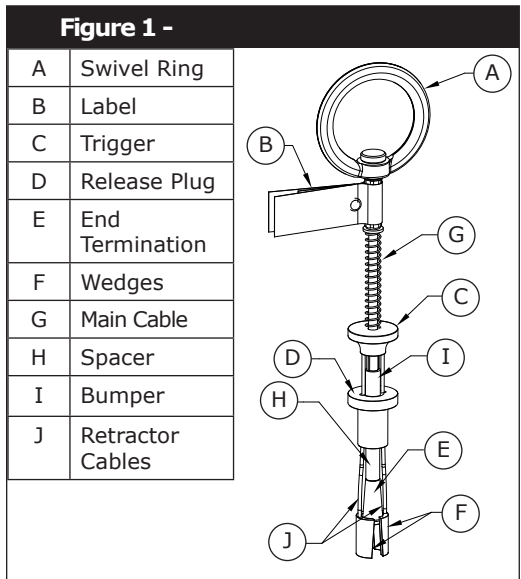

**Figure 2 - Applications**

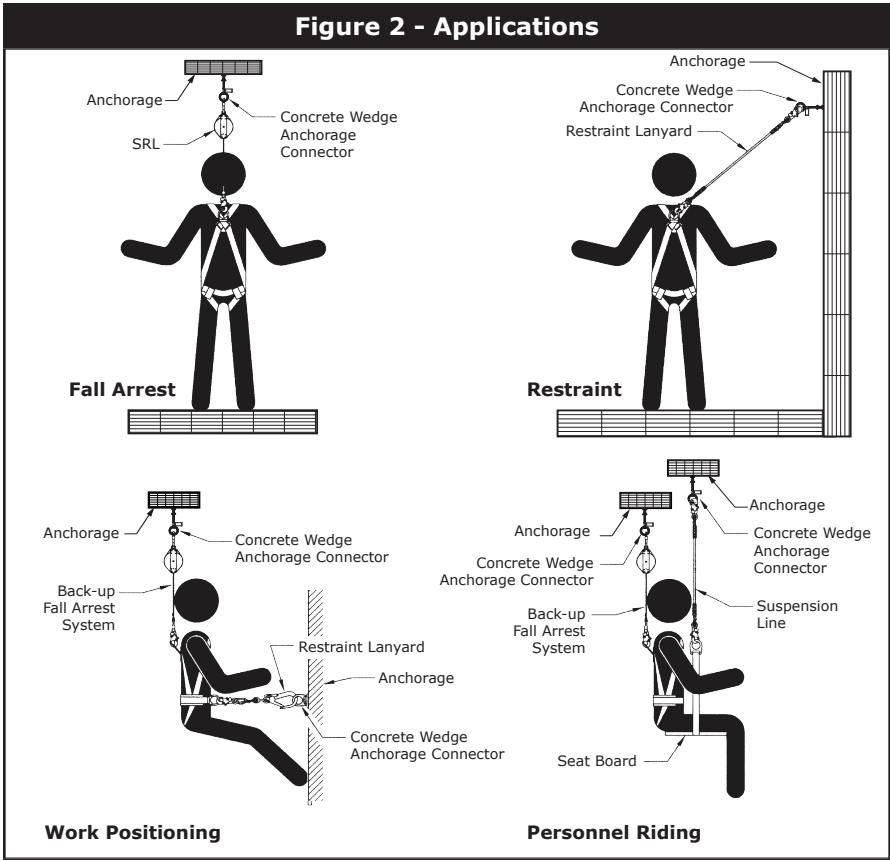

## **1.0 APPLICATIONS**

**1.1 PURPOSE:** The DBI-SALA Concrete Wedge Anchor is designed for use as an anchorage attachment point for a personal fall arrest system, work positioning system, personnel riding system, or rescue system. See Figure 2 for application illustrations.

- A. PERSONAL FALL ARREST:** The Concrete Wedge Anchor is used as a component of a personal fall arrest system to protect the user in the event of a fall. Personal fall arrest systems typically include a full body harness and a connecting subsystem (energy absorbing lanyard). Maximum permissible free fall is 6 feet.
- B. RESTRAINT:** The Concrete Wedge Anchor is used as a component of a restraint system to prevent the user from reaching a fall hazard. Restraint systems typically include a full body harness and a lanyard or restraint line. No vertical free fall is permitted.

- C. WORK POSITIONING:** The Concrete Wedge Anchor is used as a component of a work positioning system to support the user at a work position. Work positioning systems typically include a full body harness, positioning lanyard, and a back-up personal fall arrest system. Maximum permissible free fall is 2 feet.
- D. PERSONNEL RIDING:** The Concrete Wedge Anchor is used as a component of a personnel riding system to suspend or transport the user vertically. Personnel riding systems typically include a full body harness, boatswains's chair or seat board, and a back-up personal fall arrest system. No vertical free fall is permitted.
- E. RESCUE:** The Concrete Wedge Anchor is used as a component of a rescue system. Rescue systems are configured depending on the type of rescue. No vertical free fall is permitted.

**1.2 LIMITATIONS:** The following application limitations must be recognized and considered before using this product:

- A. CAPACITY:** The Concrete Wedge Anchor is designed for use by persons with a combined weight (clothing, tools, etc.) of no more than 310 lbs. No more than one personal protective system may be connected at one time.

**NOTE:** For emergency rescues it may be acceptable to connect more than one system if the anchorage will support the anticipated loads.

- B. FREE FALL:** Personal fall arrest systems used with this equipment must be rigged to limit the free fall to 6 feet (ANSI Z359.1). See the personal fall arrest system manufacturer's instructions for more information. Restraint systems must be rigged so that no vertical free fall is possible. Work positioning systems must be rigged so that free fall is limited to 2 feet or less. Personnel riding systems must be rigged so that no vertical free fall is possible. Rescue systems must be rigged so that no vertical free fall is possible.
- C. FALL CLEARANCE:** There must be sufficient clearance below the user to arrest a fall before the user strikes the ground or other obstruction. The clearance required is dependent on the following factors:

- Deceleration Distance
- Free Fall Distance
- Worker Height
- Movement of Harness Attachment Element
- Elevation of D-Ring Anchorage Connector
- Connecting Subsystem Length

See the personal fall arrest system manufacturer's instructions for more information.

- D. SWING FALLS:** Swing falls occur when the anchorage point is not directly above the point where a fall occurs. See Figure 3. The force of striking an object in a swing fall may cause serious injury or death. Minimize swing falls by working as close to the anchorage point as possible. Do not permit a swing fall if injury could occur. Swing falls will significantly increase the clearance required when a self retracting lifeline or other variable length connecting subsystem is used.

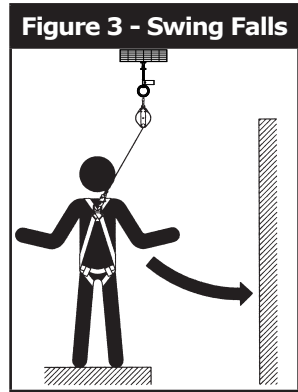

- E. ENVIRONMENTAL HAZARDS:** Use of this equipment in areas with environmental hazards may require additional precautions to prevent injury to the user or damage to the equipment. Hazards may include, but are not limited to: heat, chemicals, corrosive environments, high voltage power lines, gases, moving machinery, and sharp edges. Contact DBI-SALA if you have questions about using this equipment where environmental hazards exist.
- F. TRAINING:** This equipment must be installed and used by persons trained in its correct application and use. See section 4.0.

**1.3 APPLICABLE STANDARDS:** Refer to national standards including; ANSI Z359 (.0, .1, .2, .3, and .4) fall protection standards, ANSI A10.32, and local, state, and federal (OSHA) requirements governing occupational safety for additional information regarding personal fall arrest systems and associated components.

## 2.0 SYSTEM REQUIREMENTS

- 2.1 COMPATIBILITY OF COMPONENTS:** DBI-SALA equipment is designed for use with DBI-SALA approved components and subsystems only. Substitutions or replacements made with non-approved components or subsystems may jeopardize compatibility of equipment and may effect the safety and reliability of the complete system.
- 2.2 COMPATIBILITY OF CONNECTORS:** Connectors are considered to be compatible with connecting elements when they have been designed to work together in such a way that their sizes and shapes do not cause their gate mechanisms to inadvertently open regardless of how they become oriented. Connectors (hooks, carabiners, and D-rings) must be capable of supporting at least 5,000 lbs. (22 kN). Connectors must be compatible with the anchorage or other system components. See Section 3.8 for additional information on anchorage connections. Do not use equipment that is not compatible. Non-compatible connectors may unintentionally disengage (see Figure 4). Connectors must be compatible in size, shape, and strength. Self-locking snap hooks and carabiners are required by ANSI Z359.1 and OSHA.

**Figure 4 - Unintentional Disengagement (Rollout)**

If the connecting element to which a snap hook (shown) or carabiner attaches is undersized or irregular in shape, a situation could occur where the connecting element applies a force to the gate of the snap hook or carabiner. This force may cause the gate (of either a self-locking or a non-locking snap hook) to open, allowing the snap hook or carabiner to disengage from the connecting point.

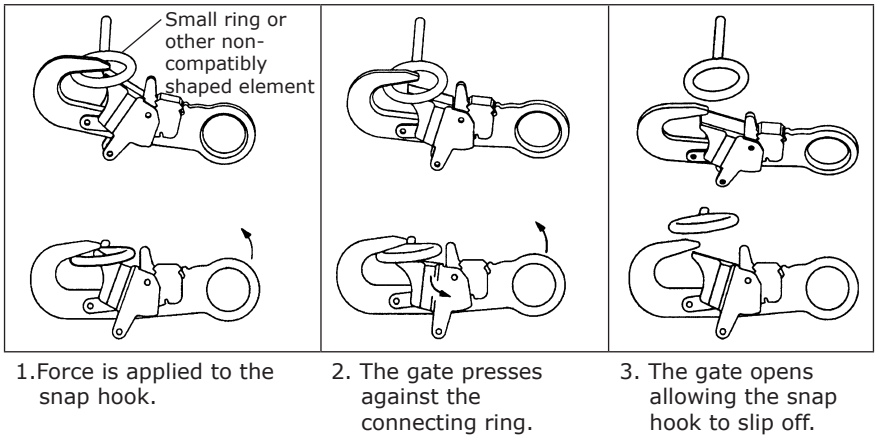

**2.3 MAKING CONNECTIONS:** Use only self-locking snap hooks and carabiners with this equipment. Only use connectors that are suitable to each application. Ensure all connections are compatible in size, shape and strength. Do not use equipment that is not compatible. Ensure all connectors are fully closed and locked.

DBI-SALA connectors (snap hooks and carabiners) are designed to be used only as specified in each product's user's instructions. See Figure 5 for inappropriate connections. DBI-SALA snap hooks and carabiners should not be connected:

- A. To a D-ring to which another connector is attached.
- B. In a manner that would result in a load on the gate.

**NOTE:** Other than 3,600 lb. (16 kN) gated hooks, large throat opening snap hooks should not be connected to standard size D-rings or similar objects which will result in a load on the gate if the hook or D-ring twists or rotates. Large throat snap hooks are designed for use on fixed structural elements such as rebar or cross members that are not shaped in a way that can capture the gate of the hook.

**Figure 5 - Inappropriate Connections**

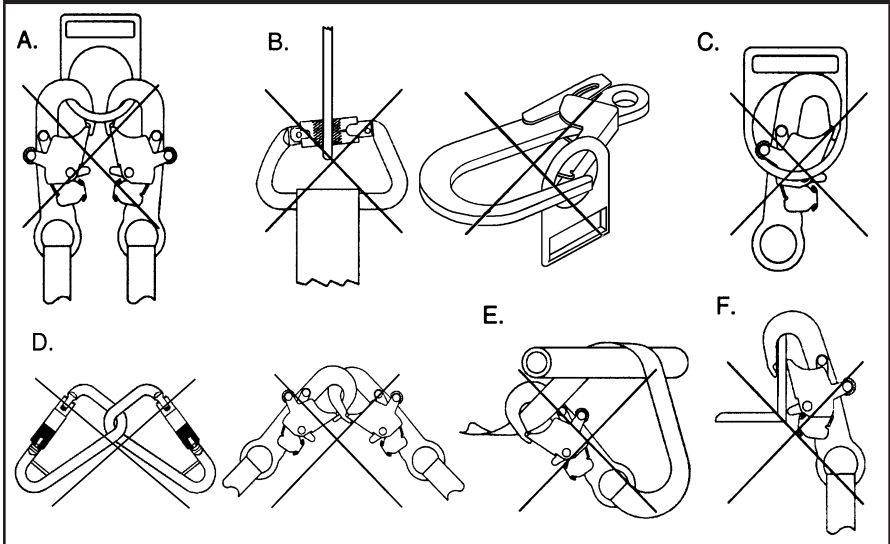

- C. In a false engagement, where features that protrude from the snap hook or carabiner catch on the anchor and without visual confirmation seems to be fully engaged to the anchor point.
- D. To each other.
- E. Directly to webbing or rope lanyard or tie-back (unless the manufacturer's instructions for both the lanyard and connector specifically allow such a connection).
- F. To any object which is shaped or dimensioned such that the snap hook or carabiner will not close and lock, or that roll-out could occur.

**2.4 PERSONAL FALL ARREST SYSTEM:** Personal fall arrest systems used with this equipment must meet applicable state, federal, OSHA, and ANSI requirements. A full body harness must be worn when this equipment is used as a component of a personal fall arrest system. As required by OSHA, the personal fall arrest system must be capable of arresting the user's fall with a maximum arresting force of 1,800 lbs., and limit the free fall to 6 feet or less. If the maximum free fall distance must be exceeded, the employer must document, based on test data, that the maximum arresting force will not be exceeded, and the personal fall arrest system will function properly.

When a free fall greater than 6 feet, and up to a maximum of 12 feet is possible, DBI-SALA recommends using a personal fall arrest system incorporating a DBI-SALA Force2 Energy Absorbing Lanyard. DBI-SALA has performed testing using the Force2 Energy Absorbing Lanyard in free falls up to 12 feet to ensure the maximum arresting force does not exceed 1,800 lbs., and the system functions properly. The results of these tests are listed in the user instruction manual provided with Force2 Energy Absorbing Lanyards.

**2.5 RESTRAINT SYSTEM:** Restraint systems used with this equipment must meet state, federal, OSHA, and ANSI requirements.

**2.6 ANCHORAGE STRENGTH:** The anchorage strength required is dependent on the application type. The following are the requirements of ANSI Z359.1 for these application types:

**A. Fall Arrest:** Anchorages selected for fall arrest systems shall have a strength capable of sustaining static loads applied in the directions permitted by the system of at least:

1. 5,000 lbs. (22.2 kN) for non-certified anchorages
2. Two times the maximum arresting force for certified anchorages.

When more than one fall arrest system is attached to an anchorage, the strengths set forth in (1) and (2) above shall be multiplied by the number of systems attached to the anchorage.

**B. Restraint:** Anchorages selected for restraint and travel restraint systems shall have a strength capable of sustaining static loads applied in the directions permitted by the system of at least:

1. 1,000 lbs. (4.5 kN) for non-certified anchorages
2. Two times the foreseeable force for certified anchorages.

When more than one restraint and travel restraint system is attached to an anchorage, the strengths set forth in (1) and (2) above shall be multiplied by the number of systems attached to the anchorage.

- C. Work Positioning:** Anchorages selected for work positioning systems shall have a strength capable of sustaining static loads applied in the directions permitted by the system of at least:

1. 3,000 lbs. (13.3 kN) for non-certified anchorages
2. Two times the foreseeable force for certified anchorages.

When more than one work positioning system is attached to an anchorage, the strengths previously set forth in (1) and (2) shall be multiplied by the number of systems attached to the anchorage.

- D. Rescue:** Anchorages selected for rescue systems shall have a strength capable of sustaining static loads applied in the directions permitted by the system of at least:

1. 3,000 lbs. (13.3 kN) for non-certified anchorages
2. Five times the foreseeable force for certified anchorages.

When more than one work positioning system is attached to an anchorage, the strengths previously set forth in (1) and (2) shall be multiplied by the number of systems attached to the anchorage.

- E. PERSONNEL RIDING:** The structure to which the Concrete Wedge Anchor is attached must sustain static loads applied in the directions permitted by the personnel riding system of at least 2,500 lbs. When more than one personnel riding system is attached to an anchorage, the strengths stated above must be multiplied by the number of personnel riding systems attached to the anchorage.

**WARNING:** Use of the Concrete Wedge Anchor for an application that does not meet the anchorage strength requirements stated in this section may result in serious injury or death.



## 3.0 INSTALLATION AND USE

**WARNING:** Do not alter or intentionally misuse this equipment. Consult Capital Safety when using this equipment in combination with components or subsystems other than those described in this manual. Some subsystem and component combinations may interfere with the operation of this equipment. Use caution when using this equipment around moving machinery, electrical hazards, chemical hazards, sharp edges, and abrasive surfaces.

**WARNING:** Consult your doctor if there is any reason to doubt your fitness to safely absorb the shock from a fall arrest or suspension. Age and fitness seriously affect a worker's ability to withstand falls. Pregnant women or minors must not use DBI-SALA equipment unless in an emergency situation.

- 3.1 BEFORE EACH USE:** Before each use of this equipment, carefully inspect it to assure that it is in serviceable condition. Refer to section 5.0 for inspection details. Do not use if inspection reveals an unsafe condition.
- 3.2 PLANNING:** Plan your system before starting your work. Take into consideration factors that affect your safety before, during, and after a fall. The following list gives some important points to consider:
- A. ANCHORAGE:** Select an anchorage capable of supporting the loads specified in Section 2.6.
  - B. SHARP EDGES:** Avoid working where system components may be in contact with or abrade against sharp edges. If working around sharp edges is unavoidable, provide protection by using a heavy pad over the exposed sharp edge.
  - C. AFTER A FALL:** Components subjected to the forces of arresting a fall must be removed from service and destroyed.
  - D. RESCUE:** The employer must have a rescue plan in place prior to the use of this equipment. The rescue plan must provide for a quick safe rescue.
- 3.3 INSTALLATION REQUIREMENTS:** The following requirements must be observed to ensure safe effective installation of the Concrete Wedge Anchor:
- A. Concrete:** The concrete in which the anchor is secured must have a compressive strength of 3,000 psi (2,685 kPa). The Concrete Wedge Anchor is not intended for use in lightweight concrete, hollow block, grout, stone, wood, steel, or any other substrate. The concrete base material must be at least 5 inches (12.7 cm) thick.

- B. Mounting Hole Location:** The allowable distance from an edge or corner for mounting the Concrete Wedge Anchor will vary with the thickness and width of the concrete. Mounting hole location requirements are as follows:

<b>Concrete Thickness:</b>	<b>Concrete Width:</b>	<b>Minimum Mounting Distance from Edge/Corner:</b>
12 in (30.5 cm)	12 in (30.5 cm)	6 in (15.3 cm)
10 in (25.4 cm)	16 in (40.6 cm)	8 in (20.3 cm)
8 in (20.3 cm)	20 in (50.8 cm)	10 in (25.4 cm)
5 in (12.7 cm)	24 in (61.0 cm)	12 in (30.5 cm)

**NOTE:** Drill bits for drilling mounting holes must conform to ANSI Standard B212.15 addressing carbide-tipped masonry drills and blanks for carbide-tipped masonry drills.

- 3.4 INSTALLATION:** To ensure effective installation of the Concrete Wedge Anchor, always observe the requirements defined in Section 3.3. Perform the following steps to install the Concrete Wedge Anchor. Refer to Figure 1 for component identification:

- Step 1.** Drill a 3 in (7.62 cm) or deeper hole at the desired mounting location with a Rotary Hammer and industrial grade 3/4" (19.05 mm) Rotary Hammer Drill Bit.

**WARNING:** Before drilling holes, inspect the hole location to prevent drilling into power transmission cables or other live utilities.

- Step 2.** The mounting hole must be free of debris for the Concrete Wedge Anchor to develop maximum anchorage. Blow all debris out of the hole with a Blow-Out Bulb or Compressed Air. If you are reusing an existing hole, inspect thoroughly for debris and a uniform surface.

- Step 3.** Place your thumb in the anchor Swivel Ring and pull up on the Trigger with two fingers until fully retracted.

- Step 4.** Insert the anchor into the mounting hole until the Release Plug seats against the concrete surface and then release the Trigger.

- Step 5.** Pull up on the anchor Swivel Ring to set the anchor.

- 3.5 REMOVAL:** To release the Concrete Wedge Anchor, push down on the Release Plug and pull up on the Trigger. If the anchor does not release, tap the Release Plug and repeat the process.

- 3.6 REUSE:** The Concrete Wedge Anchor may be reused if it has not been subjected to a fall force.

**3.7 DISPOSAL:** Dispose of the Concrete Wedge Anchor if it has been subjected to fall force or inspection (see Section 5) reveals an unsafe or defective condition.

Before disposing of the Concrete Wedge Anchor, cut the Wedges off the Retractor Cables to eliminate the possibility of inadvertent reuse.

**3.8 CONNECTIONS:** When using a hook to connect to the Concrete Wedge Anchor, ensure roll-out cannot occur. Roll-out occurs when interference between the hook and mating connector causes the hook gate to unintentionally open and release. Self-locking snap hooks and carabiners should be used to reduce the possibility of roll-out. Do not use hooks or connectors that will not completely close over the attachment object. See subsystem manufacturer's instructions for information on connecting to the Concrete Wedge Anchor.

## **4.0 TRAINING**

**4.1** It is the responsibility of the user to assure they are familiar with these instructions, and are trained in the correct care and use of this equipment. Users must also be aware of the operating characteristics, application limits, and the consequences of improper use of this equipment.

**IMPORTANT:** *Training must be conducted without exposing the trainee to a fall hazard. Training should be repeated on a periodic basis.*

## **5.0 INSPECTION**

To ensure safe, efficient operation, the Concrete Wedge Anchor should be inspected at the intervals defined in Section 5.1. See Section 5.2 for inspection procedures.

### **5.1 FREQUENCY:**

- **Before Each Use:** Visually inspect the Concrete Wedge Anchor per steps listed in Sections 5.2 and 5.3.
- **Annually:** A formal inspection of the Concrete Wedge Anchor and its connection to the structure must be performed at least annually by a competent person other than the user. The frequency of formal inspections should be based on conditions of use or exposure. See sections 5.2 and 5.3. Record the inspection results in the inspection and maintenance log in section 9.0.

**IMPORTANT:** *Extreme working conditions (harsh environment, prolonged use, etc.) may require increasing the frequency of inspections.*

**5.2 INSPECTION STEPS:** Per the intervals defined in Section 5.1, inspect the Concrete Wedge Anchor as follows. (Refer to Figure 1 for component identification):

**Step 1.** Make sure the Concrete Wedge Anchor is straight and is operating smoothly.

**Step 2.** Make sure the label is attached to the Concrete Anchor and is legible (see Section 8).

**Step 3.** Make sure the Main Cable and Retractor Cables are not kinked, frayed, or damaged.

**Step 4.** Make sure metal components are not damaged or excessively corroded.

**Step 5.** Make sure the Wedges and Retractor Cables operate smoothly and no metal burrs are present. Ensure Wedges do not exhibit and deformities.

**NOTE:** Record the inspection date and results in the Inspection and Maintenance Log (see Section 9.0).

**5.3 DEFECTS:** If inspection reveals a defective condition, remove the Concrete Wedge Anchor from service and dispose in the manner described in Section 3.7.

**5.4 PRODUCT LIFE:** The functional life of the Concrete Wedge Anchor is determined by work conditions and maintenance. As long as the product passes inspection criteria, it may remain in service.

## **6.0 MAINTENANCE**

**6.1 CLEANING:** After each use, blow off the Concrete Wedge Anchor with compressed air. Keep the anchor free of grease, oils, and dirt.

**6.2 STORAGE:** Store the Concrete Wedge Anchor in a clean dry environment. Avoid areas where chemical vapors may exist. Do not pile objects on top of the anchor. Thoroughly inspect the Concrete Wedge Anchor after extended storage.

## **7.0 SPECIFICATIONS**

### **7.1 MATERIALS:**

<b>Swivel Ring:</b>	Forged Steel
<b>Main Cable:</b>	Galvanized 7 x 19 Wire Rope
<b>Trigger:</b>	Aluminum
<b>Wedges:</b>	Stainless Steel
<b>Retractor Cables:</b>	Galvanized Steel
<b>Breaking Strength:</b>	5,000 lbs. (22 kN)
<b>Compliance:</b>	OSHA, ANSI Z359.1

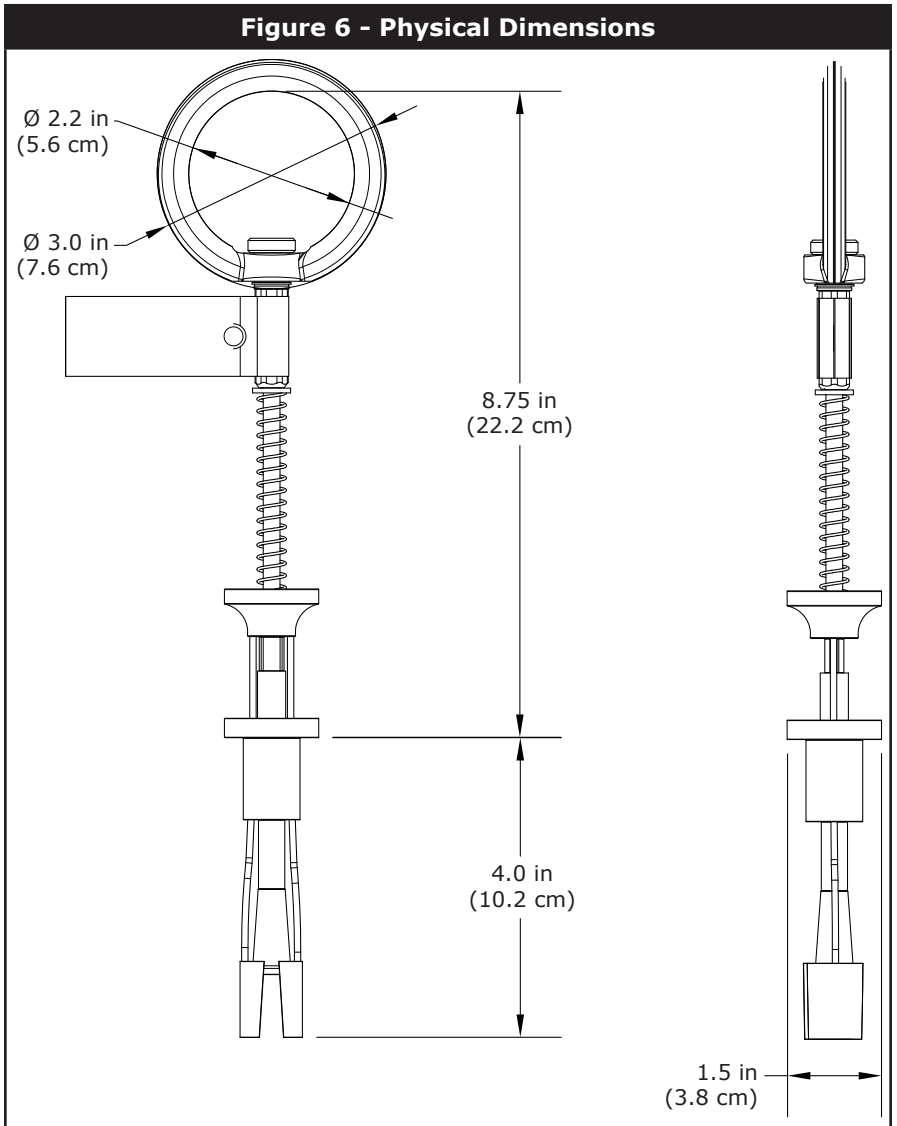

**7.2 DIMENSIONS:** See Figure 6 for physical dimensions of the Concrete Wedge Anchor.



# 8.0 LABELING

The following labels should be securely attached to the Concrete Wedge Anchor:

## FRONT OF LABEL

<p><b>▲ AVERTISSEMENT</b> – On doit respecter les directives du fabricant fournies ou publiées au moment de la livraison pour assurer une utilisation, une inspection et un entretien adéquats. La modification ou la négligence dans l'utilisation de cet équipement, ou le défaut de respecter les directives peut entraîner de graves blessures, voire la mort, l'invalidité, l'engorgement ou une détérioration. Si une inspection révèle un défaut non sécuritaire ou douteux, n'utilisez plus cet équipement. Les systèmes articulés personnalisés doivent finir les forces d'arrêt recommandées à 5 kN (1 100 lb). Évitez que le système articulés perdant ne se tienne sur des rebords horizontaux. Évitez pousser ou produire des forces de compression, de traction ou de torsion. Évitez que vos connecteurs soient soumis à des forces de cisailage ou de traction. Évitez de soulever des charges avec vos connecteurs. Évitez d'impléger dans une chute, élévation ou manuel d'entretien. Ne retirez pas l'étiquette. Pour la prévention des chutes accidentelles.</p>	<p><b>▲ WARNING</b> – Manufacturer's instructions supplied with this product at time of shipment must be followed for proper use, maintenance, and inspection. Attention or misuse of this product, or failure to follow instructions may result in serious injury or death. Inspect anchor before each use. Do not use if inspection reveals an unsafe condition. Full rated systems must meet maximum working capacity of 5000 lbs (2270 kg). Do not use on horizontal surfaces. Do not use on vertical surfaces without the capacity of this or other system components. Remove from service if involved in a fall. Refer to user manual. Do not remove label. Fall protection use only.</p>
 <p>www.captidaisy.com</p>	 <p>www.captidaisy.com</p>
<p>● Ce produit est conforme aux normes OSHA et ANSI 2359.1. <b>MATÉRIAU</b> : Armé en D en acier forgé, câble métallique galvanisé 7x19, détacheur en aluminium, gâche en le zinc à plaque de l'acier, collier et extrémité en acier inoxydable.</p> <p><b>CAPACITÉ</b> : 1 personne, 140 kg (310 lb) max.</p>	<p>● This product meets OSHA and ANSI 2359.1 requirements. <b>MATERIALS</b>: Forged Steel D-Ring, 7x19 galvanized wire rope, aluminum trigger, zinc plated carbon steel release plug, stainless steel wedge, and stainless steel end termination. <b>CAPACITY</b>: 1 person, 310 lbs max.</p>

## BACK OF LABEL

<p><b>Installation</b> – (If existing on existing hole, inspect hole for debris and a uniform surface.)</p> <p><b>Step 1:</b> Clean hole thoroughly.</p> <p><b>Step 2:</b> Use an industrial grade 3/4" rotary hammer drill bit and rotary hammer drill to drill an anchor hole to a depth of at least 5". Never use a hand drill bit. Drill hole straight into concrete.</p> <p><b>Step 3:</b> Clean hole using blow-out bulb or compressed air to remove any drilling debris.</p> <p><b>Step 4:</b> Place handle in eye of anchor and put up on trigger until fully retracted.</p> <p><b>Step 5:</b> Push down on trigger until you hear a sharp click and release the trigger.</p> <p><b>Step 6:</b> Pull on ring of anchor to set the anchor.</p>	<p><b>Anchor location:</b> If concrete is 12" thick and 12" dia, it must be 6" from any edge or corner. If concrete is 12" thick and 20" dia, it must be 10" from any edge or corner. If concrete is 5" thick, it must be 12" from any edge or corner. Concrete must have a compressive strength of at least 3000 psi. Do not use in lightweight concrete, hollow block, groll, stone, masonry wood, or any other substrate. Do not use in wet or damp conditions. Do not use in high temperatures. Do not pull up on the trigger -- if the anchor does not release, tug the trigger plug and repeat the process.</p>
<p>● <b>Installation (if existing):</b> Inspect hole for debris and a uniform surface.</p> <p>● <b>Step 1:</b> Clean hole thoroughly.</p> <p>● <b>Step 2:</b> Use an industrial grade 3/4" rotary hammer drill bit and rotary hammer drill to drill an anchor hole to a depth of at least 5". Never use a hand drill bit. Drill hole straight into concrete.</p> <p>● <b>Step 3:</b> Clean hole using blow-out bulb or compressed air to remove any drilling debris.</p> <p>● <b>Step 4:</b> Place handle in eye of anchor and put up on trigger until fully retracted.</p> <p>● <b>Step 5:</b> Push down on trigger until you hear a sharp click and release the trigger.</p> <p>● <b>Step 6:</b> Pull on ring of anchor to set the anchor.</p>	<p>● <b>Anchor location:</b> If concrete is 12" thick and 12" dia, it must be 6" from any edge or corner. If concrete is 12" thick and 20" dia, it must be 10" from any edge or corner. If concrete is 5" thick, it must be 12" from any edge or corner. Concrete must have a compressive strength of at least 3000 psi. Do not use in lightweight concrete, hollow block, groll, stone, masonry wood, or any other substrate. Do not use in wet or damp conditions. Do not use in high temperatures. Do not pull up on the trigger -- if the anchor does not release, tug the trigger plug and repeat the process.</p>
<p>● <b>Installation (if existing):</b> Inspect hole for debris and a uniform surface.</p> <p>● <b>Step 1:</b> Clean hole thoroughly.</p> <p>● <b>Step 2:</b> Use an industrial grade 3/4" rotary hammer drill bit and rotary hammer drill to drill an anchor hole to a depth of at least 5". Never use a hand drill bit. Drill hole straight into concrete.</p> <p>● <b>Step 3:</b> Clean hole using blow-out bulb or compressed air to remove any drilling debris.</p> <p>● <b>Step 4:</b> Place handle in eye of anchor and put up on trigger until fully retracted.</p> <p>● <b>Step 5:</b> Push down on trigger until you hear a sharp click and release the trigger.</p> <p>● <b>Step 6:</b> Pull on ring of anchor to set the anchor.</p>	<p>● <b>Anchor location:</b> If concrete is 12" thick and 12" dia, it must be 6" from any edge or corner. If concrete is 12" thick and 20" dia, it must be 10" from any edge or corner. If concrete is 5" thick, it must be 12" from any edge or corner. Concrete must have a compressive strength of at least 3000 psi. Do not use in lightweight concrete, hollow block, groll, stone, masonry wood, or any other substrate. Do not use in wet or damp conditions. Do not use in high temperatures. Do not pull up on the trigger -- if the anchor does not release, tug the trigger plug and repeat the process.</p>

# 9.0 INSPECTION AND MAINTENANCE LOG

SERIAL NUMBER: \_\_\_\_\_

MODEL NUMBER: \_\_\_\_\_

DATE PURCHASED: \_\_\_\_\_ DATE FIRST USED: \_\_\_\_\_

INSPECTION DATE	INSPECTION ITEMS NOTED	CORRECTIVE ACTION	MAINTENANCE PERFORMED
Approved By:			
Approved By:			
Approved By:			
Approved By:			
Approved By:			
Approved By:			
Approved By:			
Approved By:			
Approved By:			
Approved By:			
Approved By:			
Approved By:			
Approved By:			
Approved By:			

## WARRANTY

Equipment offered by DBI-SALA is warranted against factory defects in workmanship and materials for a period of two years from date of installation or use by the owner, provided that this period shall not exceed two years from date of shipment. Upon notice in writing, DBI-SALA will promptly repair or replace all defective items. DBI-SALA reserves the right to elect to have any defective item returned to its plant for inspection before making a repair or replacement. This warranty does not cover equipment damages resulting from abuse, damage in transit, or other damage beyond the control of DBI-SALA. This warranty applies only to the original purchaser and is the only one applicable to our products, and is in lieu of all other warranties, expressed or implied.



### CSG USA

3833 Sala Way  
Red Wing, MN 55066-5005  
Toll Free: 800.328.6146  
Phone: 651.388.8282  
Fax: 651.388.5065  
solutions@capitalsafety.com

### CSG Canada Ltd.

260 Export Boulevard  
Mississauga, Ontario L5S 1Y9  
Toll Free: 800.387.7484  
Phone: 905.795.9333  
Fax: 905.795.8777  
sales.ca@capitalsafety.com

[www.capitalsafety.com](http://www.capitalsafety.com)



Certificate No. FM 39709